

Product Specification

UK Model No. - RLF12Y

**GPH – 1 US Gallon = 3.7 litres
This model is supplied in 240v**

Models

- RLF12 delivers 12 gallons of chilled water per hour, and is an efficient chilling unit for in-a-wall or remote installation.

Standard Features

- Waterways Are Lead-Free In Materials & Construction
- Made of Heavy Gauge Galvanized Steel
- High-Efficiency Cooling Tank and Coil
- Refrigerant R-134a
- Limited 5-Year Warranty

Installation

- Wall-mounting cradle and stainless steel ventilating grille are available at extra cost for in-a-wall installation.
- Shipped with complete instructions.

Accessories

- Wall Mounting Cradle and Stainless Steel Grille (030101-001)
- Shelf Support (026929)

Limited 5-Year Warranty (Continental limits of the United States and Canada): Five years from date of installation on the sealed refrigeration system and most component parts. Detailed warranty certificate enclosed with each water cooler; sample copy available upon request.

Components in chilling packages are lead free as defined by the Safe Drinking Water Act Amendments of 1986, and the Lead Contamination Control Act of 1988.



Model covered by this specification complies with all known Plumbing Codes. Listed by Underwriter's Laboratories. Certified by Canadian Standards Association, and Certified to Air Conditioning and Refrigeration Institute Standard 1010.

CE Indicates conformity to European Union Directives.

WATER CHILLERS REMOTE OR IN-A-WALL CHILLING PACKAGE



Model RLF12 Shown

Export Warranty: One year on component parts. Detailed warranty certificate enclosed with each chilling package, sample copy available upon request.

Specifications are subject to change without notice.

Copyright 1999 OASIS Corporation

Oasis® is a registered trademark of OASIS Corporation.

*Air Conditioning and Refrigeration Institute Standard Rating Condition 80°F inlet water temperature.

** Special export models available, operable on 220-240 volts, 50/60 Hz. UL, CSA and ARI certification not applicable.

Model	50°F Drinking Water 90°F Ambient Air Temperature*		115 Volts, 60 Hz			Net Weight (Approx.)
	Rated Capacity GPH	Base Rate GPH	Compr. HP	Full Load Amps	Rated Watts	
RLF12**	12.0	12.0	1/3	8.7	620	50 Lbs.

OASIS Corporation

265 North Hamilton Road ♦ PO Box 13150
Columbus, Ohio 43213-0150 U.S.A.
1.800.646.2747

www.OasisWaterCoolers.com

Oasis® is a registered trademark of OASIS Corporation
 Specifications are subject to change without notice
 Copyright 1999 OASIS Corporation

OASIS Corporation
 265 North Hamilton Road ♦ PO Box 13150
 Columbus, Ohio 43213-0150 U.S.A.
 1.800.646.2747 ♦ www.OasisWaterCoolers.com

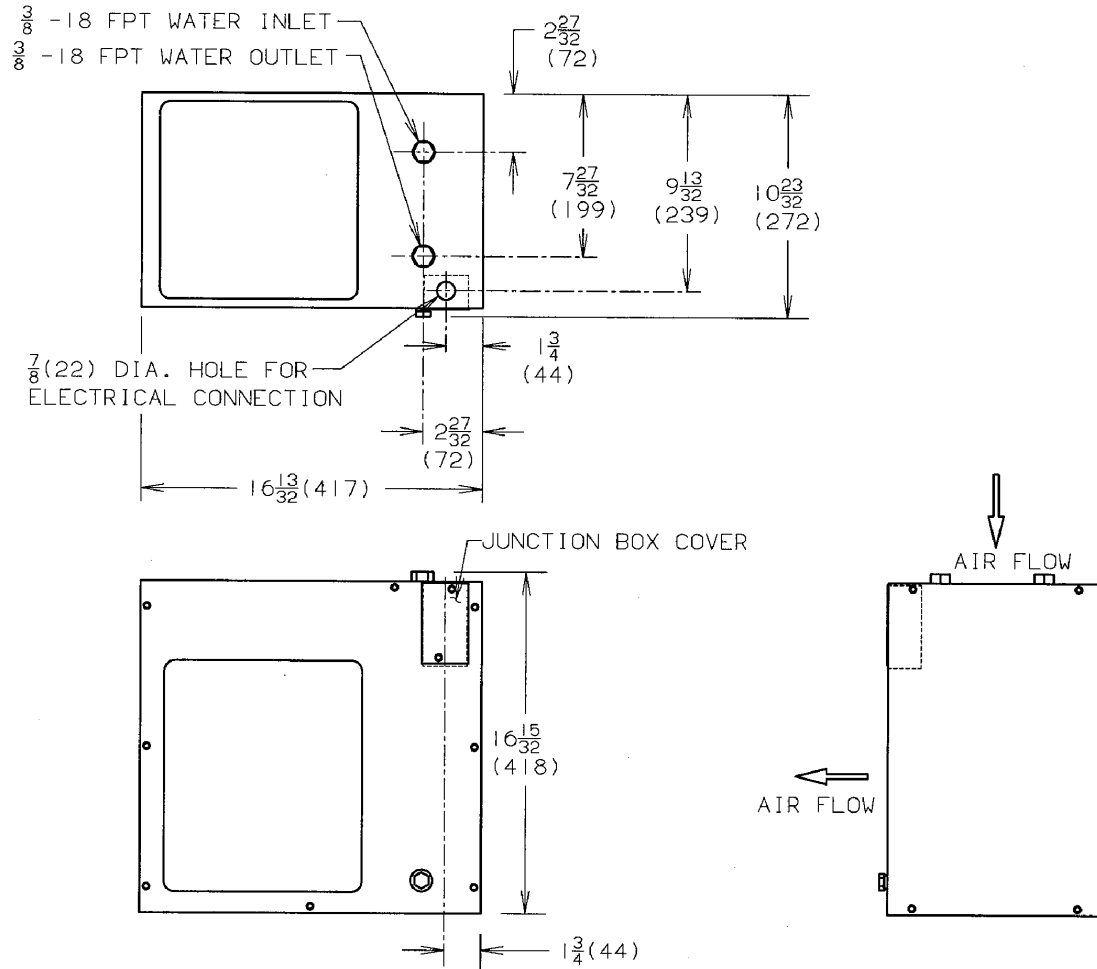

NOTES:

1. ALLOW 5 INCHES (127 MM) MIN. PER VENTILATED SIDE.
2. ALL DIMENSIONS ARE IN INCHES. DIMENSIONS IN PARENTHESES () ARE IN MILLIMETERS.

THIRD ANGLE PROJECTION 	ROUGHING-IN AND DIMENSIONAL DRAWING
----------------------------	---

Models RLF8 and RLF12